



Maximize Xylene Loop profitability

Capture significant energy savings/debottleneck your facility

Energy lives here™

The LPI process is the latest generation of liquid phase isomerization technology and is available for license by ExxonMobil directly, as well as by Axens as part of the ParamaX® technology suite for grassroots aromatics complexes.

LPI flowscheme

The following simplified flowscheme shows the LPI process in a typical fractionation and recovery section of an aromatics complex.

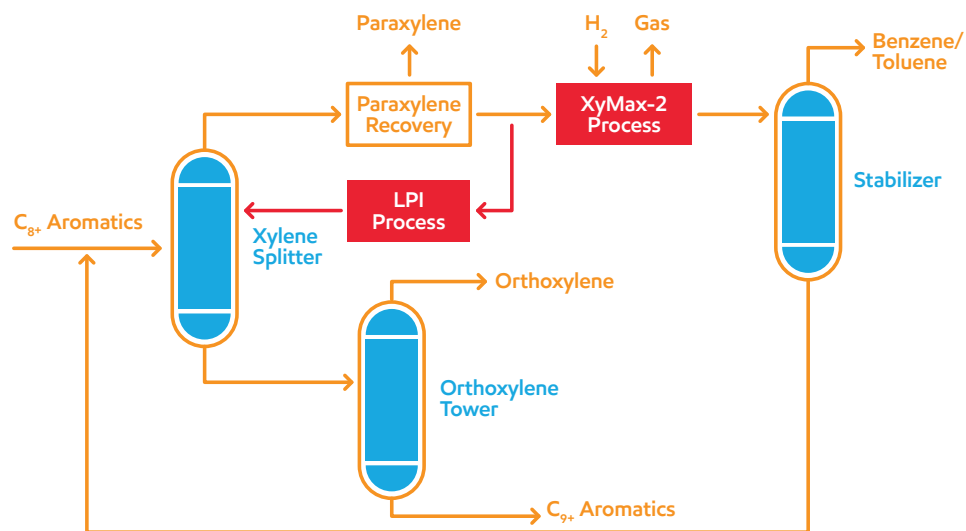

Key benefits

- \$ **Reduced capital costs**
 - Smaller vapor phase isomerization unit – grassroots
 - Simpler unit configuration
- \$ **Inexpensive debottlenecks**
- 🔄 **Long catalyst cycles**
 - Consistent with modern turnaround schedules
- 📈 **Improved process performance**
 - Significant energy savings
 - Low temperature operation
 - Ultra-low xylenes losses
 - High PX selectivity

LPI process: significant energy savings, ultra-low xylenes losses, inexpensive debottlenecking

The LPI process is the latest addition to ExxonMobil's portfolio of xylenes isomerization processes available for license. The technology operates at low temperature with xylene losses less than the best performing vapor phase isomerization technology, the XyMaxSM-2 process. The LPI process can be deployed in parallel with vapor phase isomerization units in existing plants, yielding both energy savings and debottlenecking opportunities. Because of its very low EB conversion per pass, the LPI process is often operated in combination with a vapor phase isomerization process, where most EB removal is achieved. However, in situations where the C8 aromatics stream to be isomerized contains very low EB, xylenes isomerization can be carried out via the LPI process only, and EB purge is managed by other means.

The LPI process offers the following advantages:

- Significant energy savings
 - Low temperature operation
 - Elimination of two costly steps - (1) raffinate vaporization and (2) isomerate condensing
 - Reduced traffic through the high temperature vapor phase isomerization unit
- Ultra-low xylene losses
- Low catalyst costs
- Low metallurgy costs
- Debottlenecking opportunity for existing plants or significant reduction of the vapor phase isomerization unit size in grassroots facilities
- High paraxylene selectivity
- Long cycles consistent with modern aromatics complexes turnaround schedule

Support from initial consultation throughout the life of the operation:

- Initial discussions to confirm client objectives and tailor the solution
- Detailed yield estimate
- Feasibility study
- Commercial proposal
- Process design package
- Technology transfer, training, catalyst loading and start-up support
- Technology improvement
- Performance monitoring and technical assistance throughout the life of the catalyst

About us

ExxonMobil helps refiners and petrochemical manufacturers increase capacity, lower costs, improve margins, reduce emissions and operate safe, reliable and efficient facilities. Along with a commitment to helping to implement best practices and to achieve better results, we provide cutting-edge proprietary catalysts and license advantaged process technologies for refining, gas and chemical needs.

Significant energy savings are demonstrated at multiple deployments of the LPI process

Collaborate with us today.
catalysts-licensing.com

©2018 ExxonMobil. ExxonMobil, the ExxonMobil logo, the interlocking "X" device and other product or service names used herein are trademarks of ExxonMobil, unless indicated otherwise. This document may not be distributed, displayed, copied or altered without ExxonMobil's prior written authorization. To the extent ExxonMobil authorizes distributing, displaying and/or copying of this document, the user may do so only if the document is unaltered and complete, including all of its headers, footers, disclaimers and other information. You may not copy this document to or reproduce it in whole or in part on a website. ExxonMobil does not guarantee the typical (or other) values. Any data included herein is based upon analysis of representative samples and not the actual product shipped. The information in this document relates only to the named product or materials when not in combination with any other product or materials. We based the information on data believed to be reliable on the date compiled, but we do not represent, warrant, or otherwise guarantee, expressly or impliedly, the merchantability, fitness for a particular purpose, freedom from patent infringement, suitability, accuracy, reliability, or completeness of this information or the products, materials or processes described. The user is solely responsible for all determinations regarding any use of material or product and any process in its territories of interest. We expressly disclaim liability for any loss, damage or injury directly or indirectly suffered or incurred as a result of or related to anyone using or relying on any of the information in this document. This document is not an endorsement of any non-ExxonMobil product or process, and we expressly disclaim any contrary implication. The terms "we," "our," "ExxonMobil Chemical" and "ExxonMobil" are each used for convenience, and may include any one or more of ExxonMobil Chemical Company, Exxon Mobil Corporation, or any affiliate either directly or indirectly stewarded.